

### A COMBINED FLUSH TANK AND MANHOLE.

A combination of a manhole and flush tank in one chamber has been included in the sewerage system of Newport News, and in some other systems for which Mr. Alex. Potter, Assoc. M. Am. Soc. C. E., has been, or is, engineer. The idea was suggested by Mr. Wm. Mackintosh, of Mr. Potter's staff. We are indebted to Mr. Potter for bringing the device to our attention, and for the tracing from which the accompanying illustration was prepared.

As will be seen from the illustration, a lid, or plug, inserted in the end of a special, is provided for draining the chamber when it is desired to use it as a manhole. Room for removing the plug is secured by placing the long leg of the syphon on one side of the chamber. The extra expense involved in the adoption of this device is so very small as to require very little advantage in return to justify the outlay.

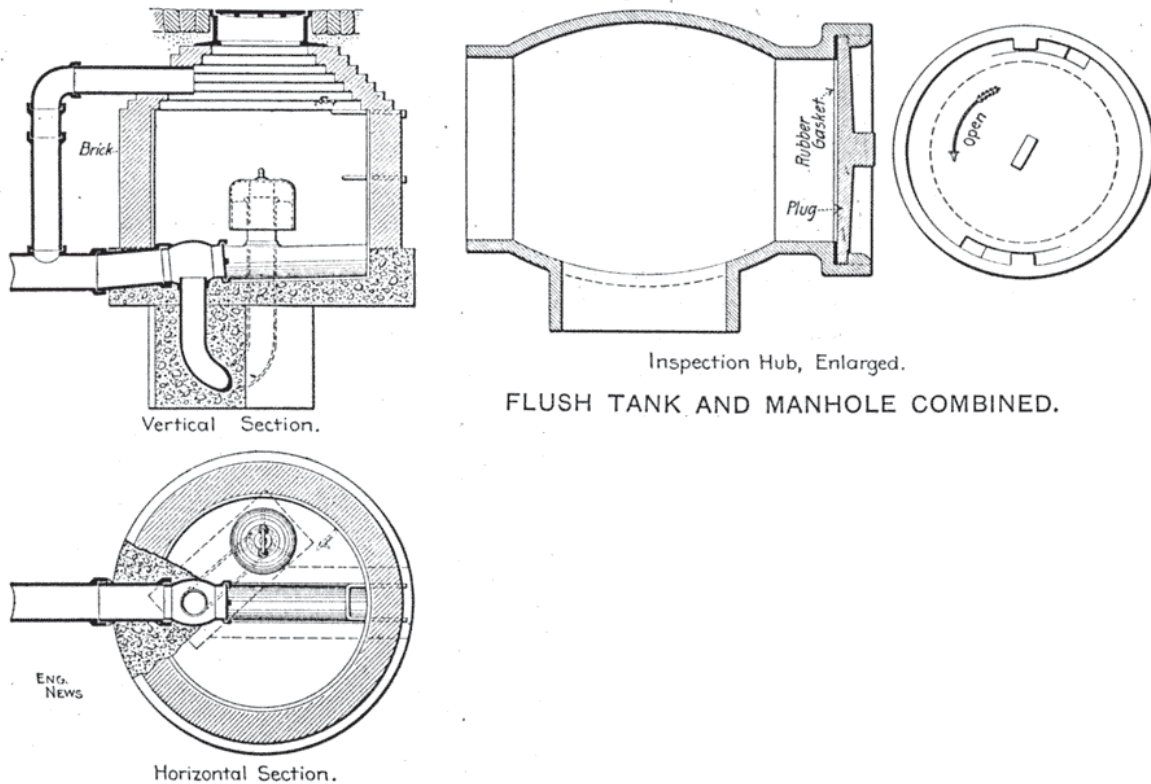

Inspection Hub, Enlarged.  
FLUSH TANK AND MANHOLE COMBINED.